

Aeotec Heavy Duty Smart Switch Gen5.

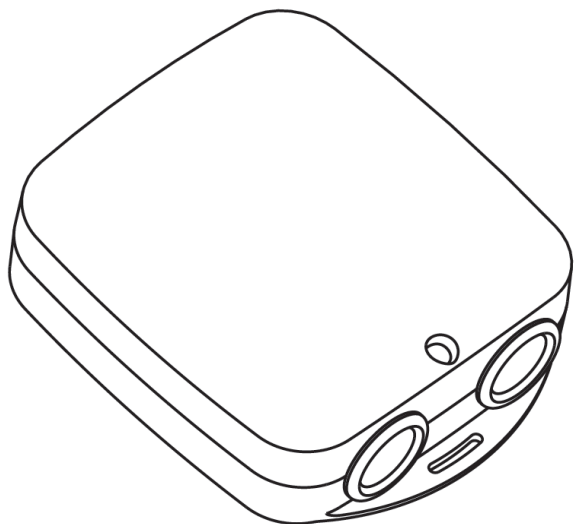

Heavy Duty Smart Switch Gen5 (<http://aeotec.com/z-wave-plug-in-switch>) has been crafted to power connected lighting using **Z-Wave Plus** (<http://aeotec.com/z-wave-plus>). It is powered by Aeotec's **Gen5** (<http://aeotec.com/z-wave-gen5>) technology.

To see whether Heavy Duty Smart Switch Gen5 is known to be compatible with your Z-Wave system or not, please reference our **Z-Wave gateway comparison** (<http://aeotec.com/z-wave-gateways>) listing. The **technical specifications of Heavy Duty Smart Switch Gen5** (<https://aeotec.freshdesk.com/solution/articles/6000167191-heavy-duty-smart-switch-gen5-technical-specifications->) can be viewed at that link.

Familiarize yourself with your Heavy Duty Smart Switch Gen5.

Package Contents:

- Heavy Duty Smart Switch Gen5
- 8AWG Wire terminal (x8)
- 10AWG Wire terminal (x8)
- Screws (x2)
- Instruction Manual

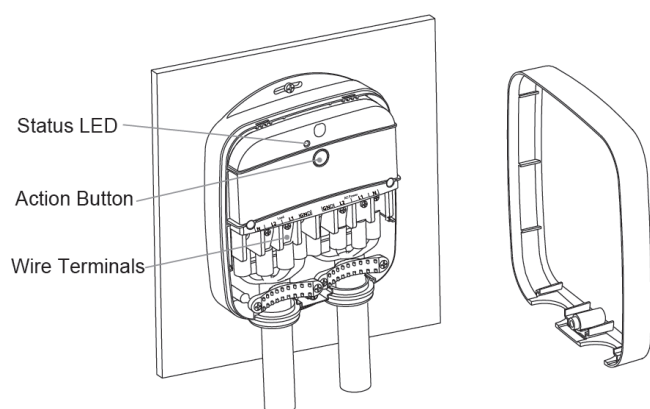

Action button: Used for Heavy Duty Smart Switch Z-Wave network inclusion and exclusion and to manually turn on or off.

Status LED: Indicates your Heavy Duty Smart Switch's status. (While unpaired, this LED will blink slowly constantly).

Terminals: There are two groups of terminals. As marked, mains power is to be connected to AC Power and the electric load to Load.

Important safety information.

Warning: Be careful of electric shock. Only installation and maintenance personnel should operate this button.

Please read this and other device guides carefully. Failure to follow the recommendations set forth by Aeotec Limited may be dangerous or cause a violation of the law. The manufacturer, importer, distributor, and / or reseller will not be held responsible for any loss or damage resulting from not following any instructions in this guide or in other materials.

A licensed electrician with knowledge and understanding of electrical systems and safety should complete the installation.

Keep product away from open flames and extreme heat. Avoid direct sun light or heat exposure.

Heavy Duty Smart Switch Gen5 current can not exceed 40 amps.

Contains small parts; keep away from children.

Quick Start.

Important: Heavy Duty Smart Switch Gen5 must wired behind an air break switch / circuit breaker for safety.

Before wiring, you must switch off the air break switch and confirm that the circuit power is down. If the air break switch is out of sight, please lock it to "OFF" position and tag it to prevent unexpected application of power.

1. Mount your Heavy Duty Smart Switch on a wall as shown:

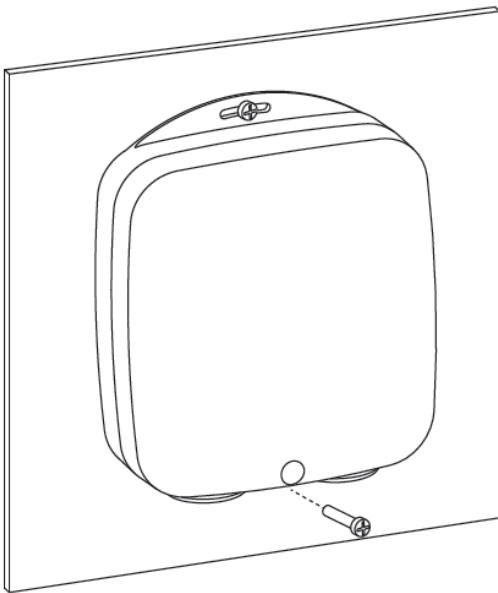

2. Loosen your Heavy Duty Smart Switch's lower screw to release its shell. Remove the shell to reveal the inner electronics:

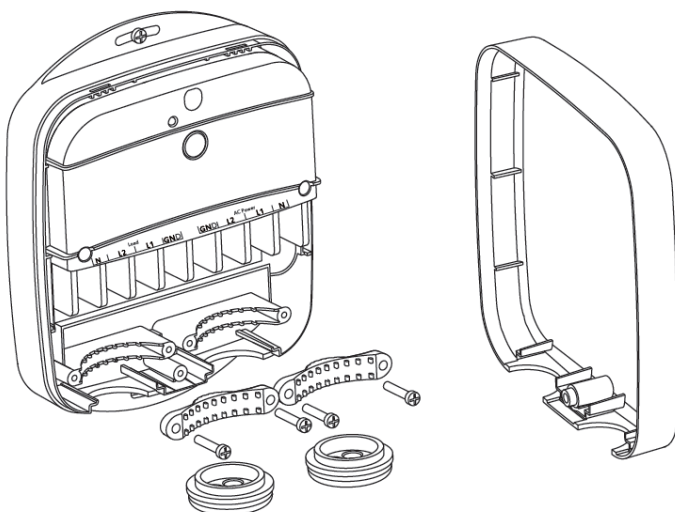

3. Prepare the wires you will be attaching to your Heavy Duty Smart Switch by stripping them to the necessary length. Add wire terminals to each wire.

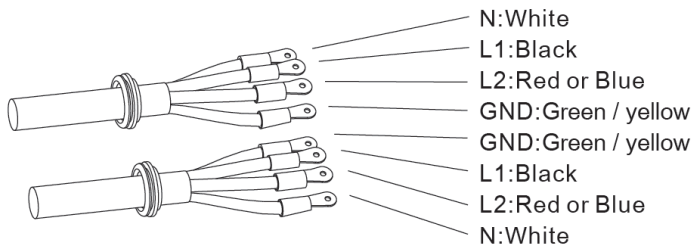

In regards to IEC 60446 wiring color mark standards in the EU where only Neutral, L1, and Ground are present (L2 and L3 do not exist for the EU model):

N = Blue
 L1 = Brown
 GND = Yellow-Green

4. Wire your Heavy Duty Smart Switch according to the following diagram. As shown below, connect each live lines from Air Break Switch to the corresponding terminals marked L1 AND L2 on your Heavy Duty Smart Switch. If there is a Neutral line and GND from the Air Break Switch, please respectively connect them to the terminals labelled N and GND. Similarly, wire the electric load with your Heavy Duty Smart Switch. As a final step, tighten the screws to the wire terminals. (Note: Air Breaker is the same as Circuit Breaker)

Important: You must make sure the wire terminals are connected firmly with each corresponding terminal on your Heavy Duty Smart Switch.

Please pay attention to the power and current of equipment. If the current is less than 32A, you can use AWG10 wire. If the current exceeds 32A, please use AWG8 wire.

Warning: Device current can not exceed 40A.

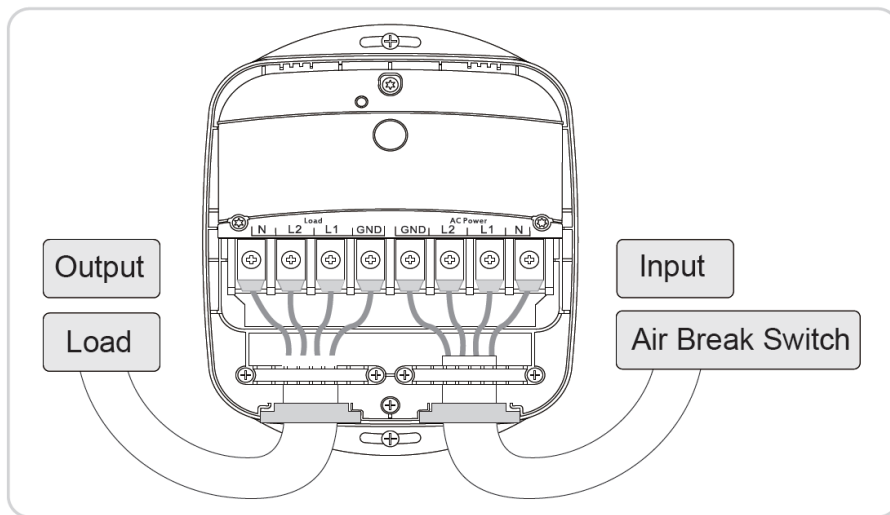

5. Power on your Heavy Duty Smart Switch. At this stage you need to add it to your Z-Wave network. If you're using an Aeotec Z-Stick or Minimote, please refer the "Z-Wave Network Instructions" section of this user guide. If you're using an alternative gateway, please refer to the respective section of its user manual using your Heavy Duty Smart Switch's Action Button to put it into inclusion mode.

6. The product can be mounted on a wall or surface. To do so, drill a $\varnothing 2.5\text{mm}$ hole that corresponds to the up upper part of your switch. Drill a second hole 138mm directly below then Affix the screws. Your installation is now complete.

Note:

1. Your switch should be installed in a ventilated area with good heat dissipation.
2. Your switch should access to the protective earth (green/yellow) line.
3. Your switch should have front-end access to a short-circuit protection.
4. Only professionals should install, repair, or open your switch's casing

Alternative Wiring Schematics: You may find other wiring schematics for using 120VAC (1 phase), 240VAC (2 phase), or EU based applications here:
Wiring Schematics (<https://aeotec.freshdesk.com/solution/articles/6000108707-heavy-duty-smart-switch-gen5-wiring-diagrams->).

Z-Wave network instructions.

Your Heavy Duty Smart Switch must be paired with a Z-Wave network before it can receive wireless commands or report the energy consumption of the attached electronics.

Note: The LED on your Heavy Duty Smart Switch will blink if it is not currently paired with a Z-Wave network.

Tip: Turn off any devices connected to your Heavy Duty Smart Switch before adding or removing it to/from a Z-Wave network. This will help to prevent load damage.

Adding your Heavy Duty Smart Switch Gen5 to a Z-Wave network.

Pairing your Heavy Duty Smart Switch Gen5 into your existing Z-Wave network.

1. Place your gateway or controller into Z-Wave pair or inclusion mode. (Please refer to your controller/gateway manual on how to do this)
2. Press the Action Button on your Switch.
3. If your switch has been successfully linked to your network, its LED will no longer blink. If linking was unsuccessful, the LED will continue to blink.

Advanced functions.

Removing your Heavy Duty Smart Switch Gen5 from a Z-Wave Network.

Unpairing your Heavy Duty Smart Switch Gen5 from your existing Z-Wave network

1. Place your gateway or controller into Z-Wave unpair or exclusion mode. (Please refer to your controller/gateway manual on how to do this)
2. Press the Action Button on your Switch.
3. If your switch has been successfully unlinked to your network, its LED will begin to blink. If linking was unsuccessful, the LED will return to its last LED state.

Turn your Heavy Duty Smart Switch Gen5 on or off.

Your Heavy Duty Smart Switch can be turned on or off through the use of Z-Wave commands built into Z-Wave certified controllers and gateways. The specific Z-Wave commands supporting this function are the Basic Command Class and Binary Switch Command Class. Please consult the operation manual for your Z-Wave network controller for specific instructions on controlling your Heavy Duty Smart Switch.

Monitoring power consumption.

Your Heavy Duty Smart Switch can report Watts energy usage or kWh energy usage to a Z-Wave gateway or controller. If this function is supported by the gateway/controller, your energy consumption will be displayed within its user interface. The specific Z-Wave commands supporting energy monitoring are the Meter Command Class and Multilevel Sensor Command Class. Automatic reports go to association group 1, which is set up via the Association Command Class. Please consult your gateway/controller manual for instructions on monitoring energy consumption through your Heavy Duty Smart Switch.

More advanced configurations.

The Smart Switch Gen5 has a longer list of device configurations that you can do with Smart Switch Gen5. These are not exposed well in most gateways, but at the least, you can manually set configurations through most Z-Wave gateways available. These configuration options may not be available in a few gateways.

You can find the configuration sheet here: <https://aeotec.freshdesk.com/helpdesk/attachments/6052990296>
(<https://aeotec.freshdesk.com/helpdesk/attachments/6052990296>)

If you have any questions on how to set these, please contact support and let them know what gateway you are using.
